



MARRIOTT MHR
INTERIOR SIGNAGE PACKAGE

We Make Ordering Easy!

WAYFINDING

Send Graphics Systems, Inc. your hotel's floorplan and let us assist with your signage order. Our experienced wayfinding staff will determine your property's specific requirements and provide you with a detailed plan that includes a graphic of each sign, sign type, quantity, price and location, all in an easy to read format.

NO DESIGN FEES

Our talented design team will create any additional signage you require, including state and local code signage, free of charge.

NO MAP CHARGES

Our professional artists will draw your fire evacuation maps free of charge. Just send us your floorplans and we'll do the rest.

COLOR OPTION

The Marriott MHR Interior Signage Package is available with silver or gold face plates. When ordering, please specify silver or gold for your entire signage package.

Guest Room Signage



3-3/4" x 3"
RMN43 MHR
Guest Room Number
Choose Silver or Gold Faces
for Entire Signage Package



3-3/4" x 1-1/4"
ACC41B MHR
Accessible Bar



3-3/4" x 3-3/4"
RMN43 MHR
Guest Room Number with
Attached Accessible Bar

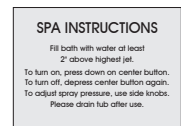

7" x 5"
SI75 MHR
Spa Instructions



5" x 4"
RDP54 MHR
Retrofit Door Plaque



6" x 3"
WLD63
Warning Decal



3" diameter
SHP33/SHV33
Sprinkler Warning
Lexan™ or Decal
available

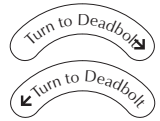

3" x 5/8"
DBV31
Deadbolt Decal

Identification Signage



8" x 6"
ID0806 MHR
Small 1-2 Line Room
Identification

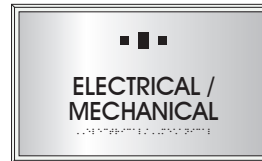

11" x 6-5/8"
ID1107 MHR
Large 1-2 Line Room
Identification

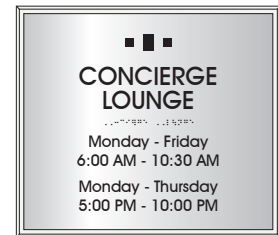

11" x 9-5/8"
ID1110 MHR
Room Identification with
Hours Information



7-5/8" x 9-5/8"
RR0810 MHR
1 Line Restroom Identification



7-5/8" x 11-5/8"
RR0812 MHR
2-3 Line Restroom Identification

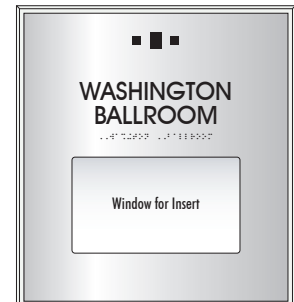

11-5/8" x 12-5/8"
MR1213 MHR
Meeting Room Identification with
Window for Insert

Informational Signage



12-5/8" x 7-5/8"
FEP1308 MHR
Elevator Fire Evacuation Plan



8" x 6"
SFF0906 MHR
Smoke Free Facility Informational

Informational Signage continued



9-5/8" x 6-5/8"
MO1007 MHR
Maximum Occupancy

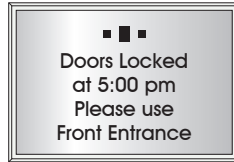

9-5/8" x 6-5/8"
INF1007 MHR
Informational



6" x 3"
INFO603 MHR
Informational



2-3/4" x 3-1/2"
ELJ0303 MHR
Elevator Level Sign



8-5/8" x 8-5/8"
INF0909 MHR
Informational

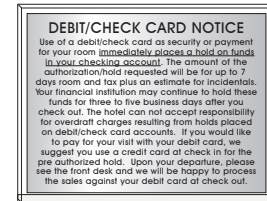
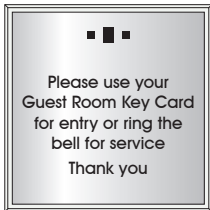

8-5/8" x 6-5/8"
BNT 0907 MHR
Debit/Check Card Informational Sign

Projection Mounted Informational Signage



12" x 4-1/4"
PRJ1204 MHR
Projection Mounted Informational



12" x 11"
PRJ1211 MHR
Projection Mounted Informational



12" x 8"
PRJ1208 MHR
Projection Mounted Informational

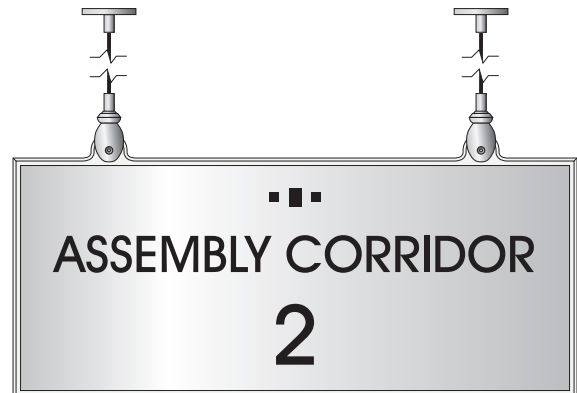

23-1/2" x 10"
CLG2410 MHR
Ceiling Mounted Informational

Directional Signage



10-1/2" x 5"
DIR1105 MHR
1-2 Line Standard Small Directional



14-1/2" x 5"
DIR1405 MHR
1-2 Line Standard Medium Directional



10-1/2" x 7-5/8"
DIR1108 MHR
3-4 Line Standard Small Directional



14-1/2" x 7-5/8"
DIR1408 MHR
3-4 Line Standard Medium Directional



10-1/2" x 9-7/8"
DIR1110 MHR
5-6 Line Standard Small Directional



14-1/2" x 9-7/8"
DIR1410 MHR
5-6 Line Standard Medium Directional

10-1/2" x 12-1/8"
DIR1112 MHR
7-8 Line Standard Small Directional

14-1/2" x 12-1/8"
DIR1412 MHR
7-8 Line Standard Medium Directional

10-1/2" x 14-3/8"
DIR1114 MHR
9-10 Line Standard Small Directional

14-1/2" x 14-3/8"
DIR1414MHR
9-10 Line Standard Medium Directional

10-1/2" x 16-5/8"
DIR1117 MHR
11-12 Line Standard Small Directional

14-1/2" x 16-5/8"
DIR1417 MHR
11-12 Line Standard Medium Directional

14-1/2" x 18-7/8"
DIR1419MHR
13-14 Line Standard Medium Directional

18-1/8" x 8-1/8"
DIR1808 MHR
1-2 Line Standard Large Directional

18-1/8" x 11-5/8"
DIR1812 MHR
3-4 Line Standard Large Directional

18-1/8" x 14-5/8"
DIR1815 MHR
5-6 Line Standard Large Directional

18-1/8" x 17-5/8"
DIR1818 MHR
7-8 Line Standard Large Directional

18-1/8" x 20-5/8"
DIR1821 MHR
9-10 Line Standard Large Directional

18-1/8" x 23-5/8"
DIR1824 MHR
11-12 Line Standard Large Directional

18-1/8" x 26-5/8"
DIR1827 MHR
13-14 Line Standard Large Directional

18-1/8" x 29-5/8"
DIR1830 MHR
15-16 Line Standard Large Directional

18-1/8" x 32-1/8"
DIR1833 MHR
17-18 Line Standard Large Directional

Directory



18-1/8" x 32-1/8"
DIR1832 MHR
Directory

Dimensional Letters

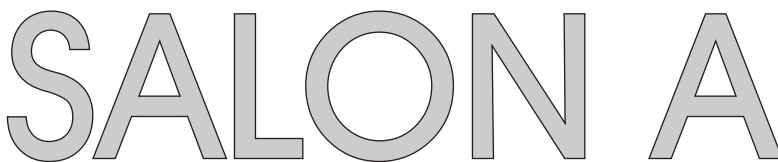

6"
MFA6 MHR
Metal Faced Acrylic Letters

Guest Room Fire Evacuation Plans

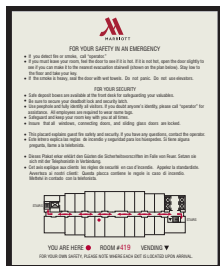

9" x 11"
FEP0911 MHR
Guest Room Fire Evacuation Plan
Option 1



23" x 10"
FEP2310 MHR
Guest Room Fire Evacuation Plan with Window for Rate/Law Card
Option 3

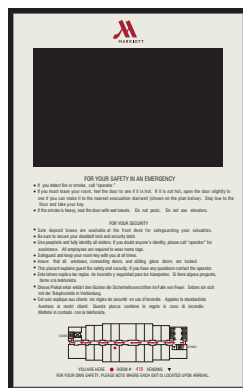

10" x 16"
FEP1016 MHR
Guest Room Fire Evacuation Plan
with Window for Rate/Law Card
Option 2

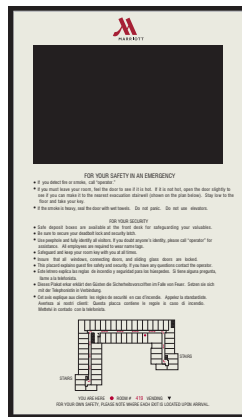

10" x 17-1/4"
FEP1017 MHR
Guest Room Fire Evacuation Plan
with Window for Rate/Law Card
Option 2B

Daily Events

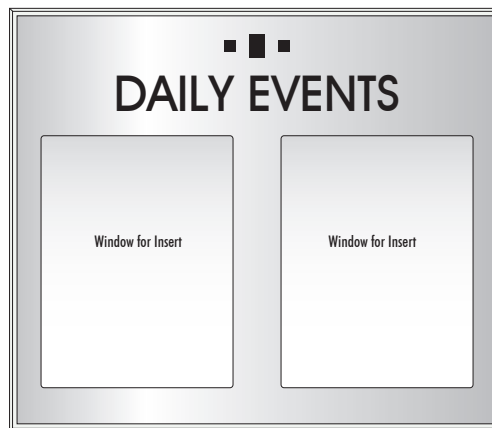

20-5/8" x 17-5/8"
DE2118 MHR
Daily Events Board with Windows for 2 Inserts



11-5/8" x 17-5/8"
DE1218 MHR
Daily Events Board with Window for 1 Insert

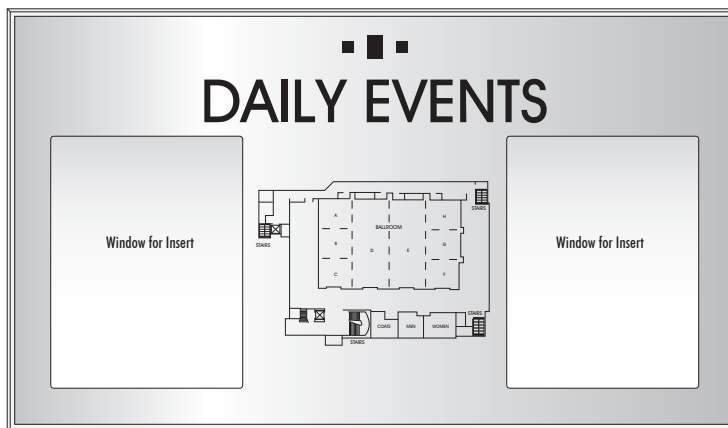

30-5/8" x 17-5/8"
DE3118 MHR
Daily Events Board with Map and Windows for 2 Inserts

Health Club Signage

WHIRLPOOL SPA USE

For your safety, it is required that you observe the following:

- Registered guests only.
- Individuals utilizing this facility do so at their own risk.
- **WARNING:** - No consumption of alcoholic beverages or food is permitted in pool area.
- It is highly recommended that the following individuals not use the whirlpool spa:
 - a) persons with present or prior heart disease, high blood pressure, or any chronic health problems.
 - b) persons under the influence of alcohol, stimulants or depressants.
 - c) pregnant women.
 - d) elderly persons.
 - e) children under the age of 10.
 - f) unsupervised children under the age of 15.
- Should you need any assistance, please contact management.
- **WARNING:** - Chemical and PH levels are in accordance with local codes and measured regularly.
- However, high heat and chemical in this spa may cause fading and/or damage to certain fabrics.
- Always practice water safety and courtesy to others. • Report any unsafe conditions to the management.
- All persons shall bathe with warm water and soap before entering spa.
- Any persons known or suspected of having a communicable disease shall not use the spa.
- Spitting or blowing the nose in the spa is prohibited. • Do not use alone.
- Observe a reasonable time limit, (preferably not longer than 15 minutes), then shower, cool down and if you wish, return for another brief stay. Long exposures may result in nausea, dizziness or fainting.
- Food and glass objects are not permitted in spa area. • Maximum temperature 104° Fahrenheit.

MAXIMUM BATHING LOAD

9

Thank you for your attention and cooperation.

23-1/2" x 18"
WR2418 MHR
Whirlpool Rules

POOL AREA USE

For your safety, it is required that you observe the following:

- Registered guests only.
- All children under 14 must be with an adult.
- Running and horseplay are prohibited.
- Appropriate swim wear required.
- Diving strictly prohibited.
- Shirts and shoes required in the hotel lobby.
- Glassware is not permitted within the pool area.
- Only flexible swim-aids are permitted.
- Be aware of depth markings at all times.
- Report any unsafe conditions or violations to the management immediately.
- Individuals assume the risk for any injuries sustained while using pool facilities.
- Always practice water safety and courtesy.
- Shower before entering pool.
- Children who are not toilet trained must wear swim diapers with rubber pants over them.

Thank you for your attention and cooperation.

23-1/2" x 18"
PR2418 MHR
Pool Rules

EXERCISE ROOM USE

For your safety, it is required that you observe the following:

- Individuals utilizing this facility do so at their own risk.
- Individuals should not undertake exercise routines unless physically qualified and have a physician's approval to do so.
- It is highly recommended that the following individuals not use the exercise equipment:
 - persons under the influence of alcohol, stimulants or depressants
 - unsupervised children under the age of 16
 - children under the age of 14
- Should you need any assistance please contact the Front Desk.
- Equipment should be used in the presence of others.
- Shoes and appropriate exercising attire are necessary.
- Smoking is prohibited.
- Always practice safety and courtesy to others.
- Report any unsafe conditions to management.

Thank you for your attention and cooperation.

23-1/2" x 18"
EXR2418 MHR
Exercise Room Use

WARNING: THIS FACILITY IS UNATTENDED AND IS NOT CONTINUOUSLY MONITORED. THIS FACILITY IS PROVIDED TO OUR GUESTS AS AN AMENITY AND SHOULD NOT BE CONSIDERED A FULL-SERVICE FITNESS FACILITY.

GUESTS SHOULD ONLY USE THIS FACILITY AFTER THEY HAVE CONSULTED A PHYSICIAN TO DETERMINE IF THE USE OF THE EQUIPMENT IN THIS FACILITY IS APPROPRIATE.

AN AUTOMATED EXTERNAL DEFIBRILLATOR HAS BEEN PROVIDED, IN CASE OF AN EMERGENCY.

AS WITH ANY MEDICAL EMERGENCY, 9-1-1 SHOULD BE NOTIFIED PRIOR TO THE RENDERING OF ANY FIRST AID ASSISTANCE.

10" x 10"
AED W1 MHR
Automated External Defibrillator
For Unattended Fitness Center

WARNING: THIS FACILITY IS ATTENDED ONLY DURING THE HOURS OF . . . THIS FACILITY IS NOT ATTENDED AT TIMES OUTSIDE OF THESE HOURS. THIS FACILITY IS PROVIDED TO OUR GUESTS AS AN AMENITY AND SHOULD NOT BE CONSIDERED A FULL-SERVICE FITNESS FACILITY.

GUESTS SHOULD ONLY USE THIS FACILITY AFTER THEY HAVE CONSULTED A PHYSICIAN TO DETERMINE IF THE USE OF THE EQUIPMENT IN THIS FACILITY IS APPROPRIATE.

AN AUTOMATED EXTERNAL DEFIBRILLATOR HAS BEEN PROVIDED, IN CASE OF AN EMERGENCY.

AS WITH ANY MEDICAL EMERGENCY, 9-1-1 SHOULD BE NOTIFIED PRIOR TO THE RENDERING OF ANY FIRST AID ASSISTANCE.

10" x 10"
AED W2 MHR
Automated External Defibrillator
For Attended Fitness Center

NO DIVING

36" x 8"
ND3608 MHR
No Diving

Maximum
Pool Capacity
44
People

23-1/2" x 20"
PR2420 MHR
Pool Capacity

Health Club Signage continued

**NO LIFEGUARD
ON DUTY**

CHILDREN UNDER THE AGE OF 14 SHOULD NOT USE POOL WITHOUT AN ADULT IN ATTENDANCE

47-1/2" x 14"
NL4814 MHR
No Lifeguard on Duty

MOUTH-TO-MOUTH RESUSCITATION

A - AIRWAY

1. Clear the mouth.
2. Push or pull jaw into a jutting out position.



B - BREATHING

3. Pinch nose SHUT.
4. Cover victim's mouth with your mouth. BLOW until chest rises: for BABIES: cover mouth and nose.
5. Remove your mouth. Listen for return air. Repeat 12 to 15 times per minute.



CAUTION: If a neck injury sign appears, move the lower jaw forward without tilting the head to open the airway. Rest your elbow on the surface which the victim is lying. Move the lower jaw forward with both hands, one on each side.

18" x 18"
MM1818 MHR
Mouth-to-Mouth
Resuscitation

**WARNING!
NO DIVING!
SHALLOW WATER**



CRIPPLING INJURIES MAY RESULT

18" x 18"
WND1818 MHR
Warning! No Diving

SAUNA USE

For your safety it is required that you observe the following:

1. Individuals using this facility do so at their own risk.
2. Should you need any assistance, please contact management.
3. It is highly recommended that those individuals not use the sauna:
 - Persons under a physician's care or with chronic health problems
 - Persons under the influence of alcohol, stimulants or depressants
4. Smoking or exercising is prohibited in the steam room.
5. Before using, read instructions on how to operate sauna.
6. Preheat sauna to desired temperature before use, but not in excess of 170-180 degrees Fahrenheit.
7. Remove clothing and jewelry and submerge your valuables by placing them in a safe deposit box.
8. Valuables should not be left in lockers.
9. Wear a towel or a robe loosely.
10. Before entering the sauna, allow enough time to relax completely, remove shoes, relax in changing area and follow with a cool shower. (Cooling time should equal time spent in sauna).
11. After 10 minutes maximum in sauna, or when perspiration begins, leave sauna, relax in changing area and follow with a cool shower. (Cooling time should equal time spent in sauna).
12. Enter sauna again and stay 5 to 10 minutes maximum.
13. Repeat cycle not more than 2 or 3 times.
14. Always practice safety and courtesy to others.
15. Report any unsafe conditions to the management.
16. All children under 15 must be with an adult.

WARNING

- Do not exceed 30 minutes total in sauna. Excessive exposure can be harmful to your health.
- End with a brisk shower and drink a cool water.
- Some sauna bathers enjoy the "Steam Effect" of splashing water on the hot sauna rocks but only one dipper full at a time and take care to keep clear of the steam as it rises off the rocks.
- Dress when completely dry and perspiration stops or chills may result.

12" x 15"
SNR1215 MHR
Sauna Use

Parking Identification

NOTICE

You are parking and leaving your vehicle at your own risk. Please lock all doors and windows after removing any property or valuables from the vehicle. The hotel will not, in any event, be liable for loss or damage to your vehicle or property.

16" x 16"
PLW MHR
Parking Informational

Interior Stairwell Identification

FLOOR 5 FLOOR 5
STAIR A
ROOF ACCESS

5

1 THROUGH 5

**EXIT DISCHARGE
THIS FLOOR**

13" x 17"
STR1317 MHR
Interior Stairwell Identification

FLOOR 4 FLOOR 4
STAIR A
ROOF ACCESS

4

1 THROUGH 4
EXIT ON FLOOR 1

13" x 13"
STR1313 MHR
Interior Stairwell Identification

**Do NOT
Lose
Give to
Installer**



GUEST ROOM NUMBER AND ROOM IDENTIFICATION INSTALLATION

The preferred location for ADA compliancy is on the wall adjacent to the latch side of the door followed by nearest adjacent wall. A sign should NOT be mounted on the door except as a last resort.

Guest room numbers and room identification signage as well as informational and directional signage should be mounted 60" from the finished floor to the centerline of the sign.

PEEPHOLES NOTE:
Center sign vertically between peepholes if room is accessible. If room is not accessible mount Evacuation Plan 2" below peephole

CALIFORNIA EVACS (guest room) are to be mounted no higher than 48" to the bottom of the sign, above finished floor

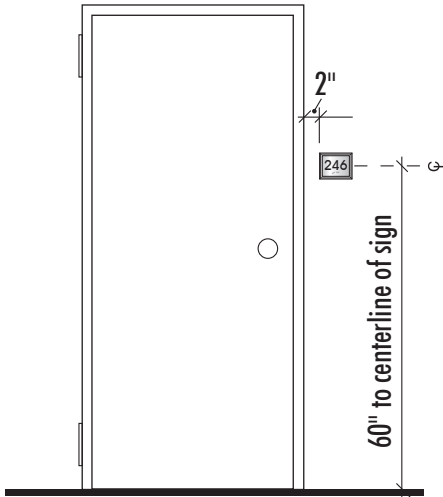

GUESTROOM NUMBER - CORRIDOR SIDE ELEVATION (NOT TO SCALE)

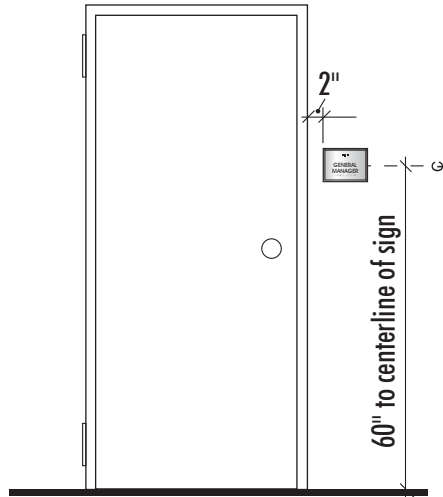

ROOM IDENTIFICATION (NOT TO SCALE)

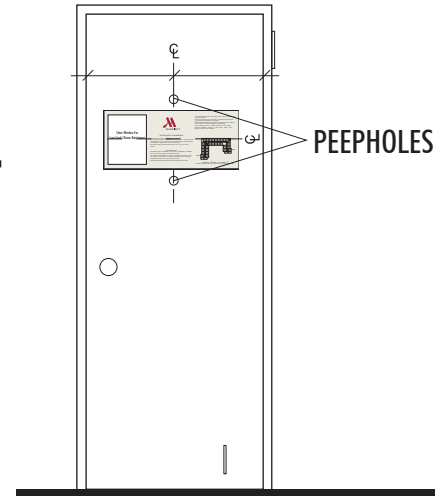

GUESTROOM EVACUATION (INTERIOR) (NOT TO SCALE)

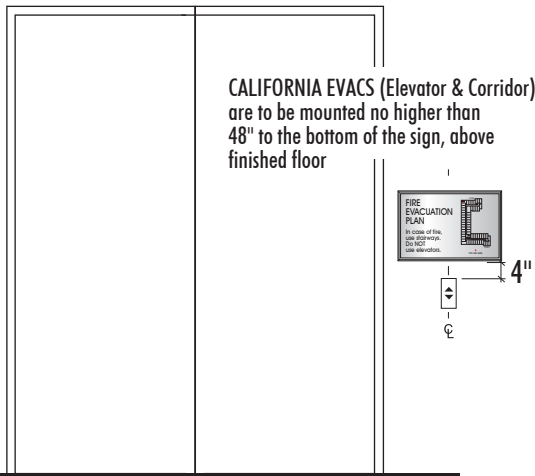

ELEVATOR EVACUATION - CORRIDOR SIDE ELEVATION (NOT TO SCALE)

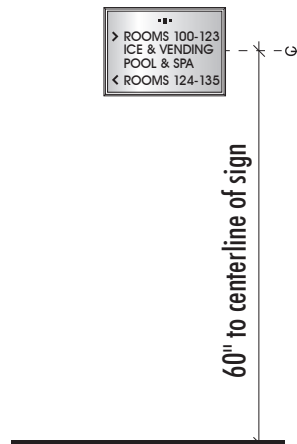

DIRECTIONAL SIGNAGE (NOT TO SCALE)

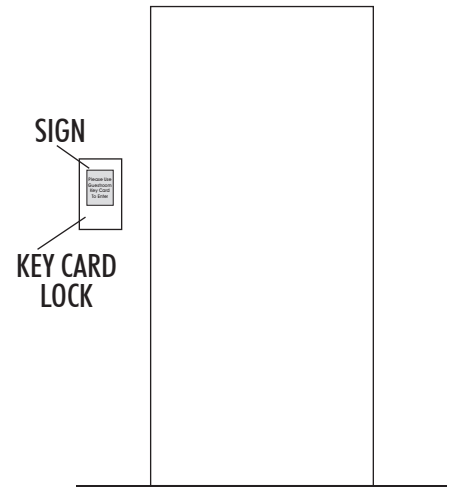

KEY CARD - CORRIDOR SIDE ELEVATION (NOT TO SCALE)

VINYL BLOCKER FOR GLASS MOUNTING

Signage that will be mounted on glass will require a vinyl blocker to hide the signage mounting tape and silicone adhesive. The vinyl blocker is mounted to the glass. The signage is mounted on top of the vinyl blocker.

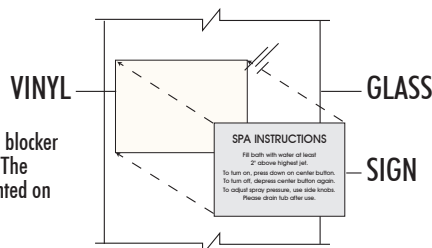



Signage Mounting Instructions

1. Installation surface must be CLEAN and DUST FREE.
2. Place a small "dot" of silicone in each corner of the sign. The "dot" should be 1/4" to 3/8" in diameter.

WARNING! FOR PRODUCTS WITH METALLIC CONTENT (brass, aluminum, silver, gold, copper, etc.) **USE ONLY NON-CORROSIVE SILICONE FOR PRODUCT INSTALLATION!** We recommend Silicone XL by M-D (Macklanburg-Duncan) which is regarded as non-corrosive to metals. **USE OF REGULAR SILICONE OR OTHER LIQUID ADHESIVES WILL VOID ANY/ALL EXPRESSED OR IMPLIED PRODUCT WARRANTIES REGARDING OXIDATION OF THE METALLIC CONTENT.**

3. Remove paper backing from foam tape.
4. Position sign in desired location and apply enough pressure to ensure the foam tape sticks to the mounting surface. The foam tape will hold the sign in place until the silicone adhesive cures.
5. If removal is required, slide a putty knife gently behind the sign and "cut" through the silicone adhesive and the foam tape.

Signs MUST be Mounted with Foam Tape AND Silicone
Tape Holds Sign Until Silicone Dries

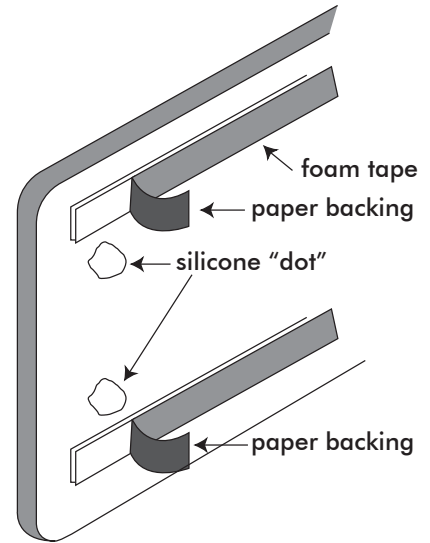

If you have any questions concerning these instructions or problems with signage installation, call 316-267-4171 for assistance.

Signage Cleaning Instructions

Do NOT clean unless signage appears soiled.

Do NOT use solvents or ammonia based cleaners. *Use of such cleaners will void all warranties.*

Use a clean, damp, non-abrasive, lint free cloth to wipe the sign surface.

Do NOT immerse sign. Excess water will damage interior grade Braille signage.

When the soil has been removed, wipe the sign with a clean, dry, non-abrasive, lint free cloth.

If you have any questions concerning these instructions, call your account executive at 316-267-4171 for assistance.

Signage Warranty

Graphics Systems, Inc. guarantees that the materials used for graphics shall be free from defects in materials, design and workmanship for a period of one (1) year from the date of acceptance (delivery).

Upon receipt of notice of failure of any part of these materials during the warranty period, new replacement parts and materials shall be furnished promptly by Graphics Systems, Inc. at no additional cost.

Graphics Systems, Inc. does not warranty abuse, vandalism or wear that occurs in daily use. Graphics Systems, Inc. does not cover damage that occurs in removal of signs.